

NCE ES

Energy saving circulating pumps for sanitary hot water



Construction

Energy saving variable speed circulating pump driven by a permanent magnet synchronous motor (pm) controlled by on board inverter. Bronze pump casing.

Applications

Hot sanitary water systems.

Operating conditions

- Liquid temperature from +2 °C to +95 °C
- Ambient temperature from +2 °C to +40 °C
- Maximum working pressure: 10 bar
- Storage: -20°C/+70°C UR 95% a 40 °C
- Certifications: in conformity with CE requirements
- Sound pressure \leq 43 dB (A).
- Minimum suction pressure: 0,3 bar at 50 °C
1,0 bar at 95 °C
- EMC according to: EN 55014-1, EN 55014-2, EN 61000-3-2, EN 61000-3-3.
- Threaded ports ISO 228: G 1, G 1 1/4, G 1 1/2.

Designation

NCE ES 25 - 40 / 130



Motor

Synchronous motor with permanent magnets.

- Motor: variable speed
- Standard voltage: single-phase 230 V (-10%;+6%)
- Frequency: 50-60 Hz
- Protection: IP 44
- Insulation class: H
- Class II appliance
- Overload protection (jammed rotor):
 - 1) automatic protection with electronic rotor release
 - 2) overload thermal protector
- Cable: phases and neutral
- Constructed in accordance with: EN 60335-1, EN 60335-2-51.

Special features on request

Brass unions.

Features

Energy saving

NCE ES is an high energy efficiency product.

Compact design

The space saving NCE ES facilitate the installation in the smaller systems.

Easy to install and to adjust

Installing the NCE ES is considerably simplified by the quick setting and power installation plug. The adjustment is simple and intuitive thanks to the ability to be able to select the optimum working point or mode via a simple LED indicator and switch.

Reliability

NCE ES features the patented self-cleaning square chamber design, which eliminates any possibility of rotor blockage.

Easy use

Operating range with fixed curves from 0,6 m to 4 m with selection of the optimum working point.

Patented

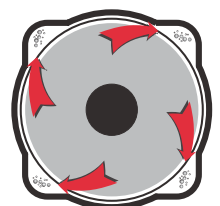

Escape routes for impurities inside the rotor chamber

Operating modes



MANUAL PROGRAMMING

(BLUE LED)

Setting the switch in any position between the MIN and MAX points, the most suitable operating curve for the installation is manually selected.

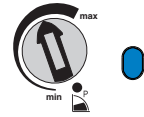

WARNING!



- The red LED indicates that the pump is not rotating but is still under tension.
- White flashing LED : plant degassing requirement, air in the system.

Characteristic curves

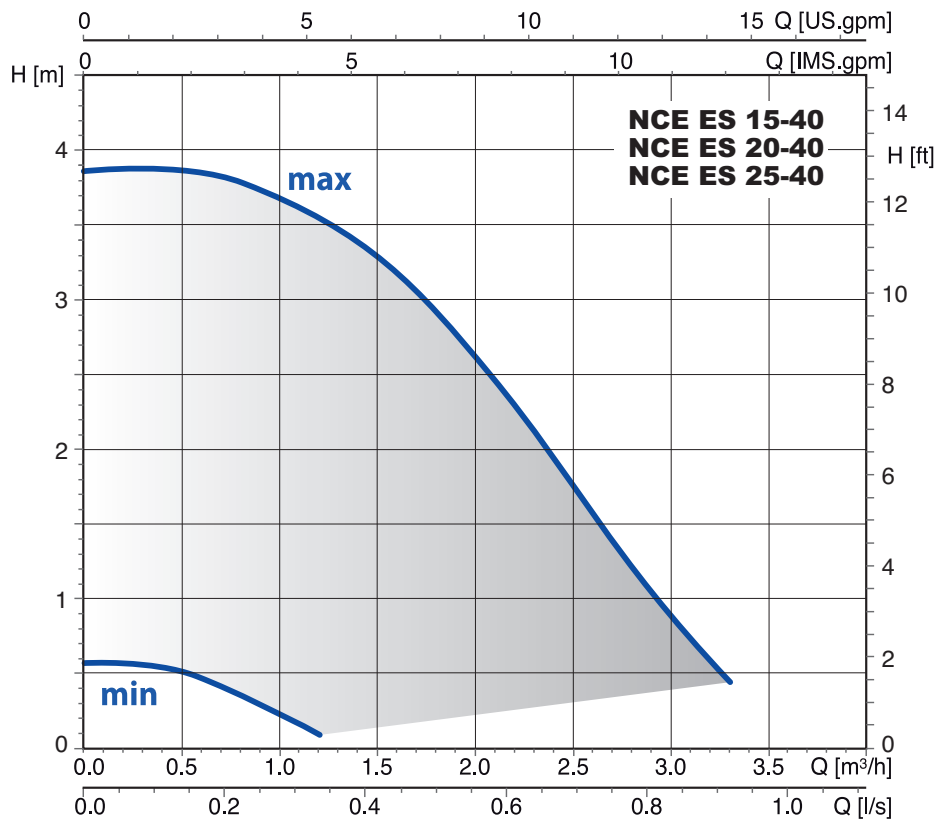

Materials

| Component | Pos. | Material |
|-----------------|------|---------------------|
| Pump casing | 1 | Bronze |
| Impeller | 2 | Composite |
| Shaft | 3 | Ceramic |
| Bearings | 4 | Carbon |
| Thrust bearing | 5 | Ceramic |
| Rotor | 6 | Composite / Ferrite |
| Winding | 7 | Copper wire |
| Electronic card | 8 | - |
| Gasket | 9 | EPDM |

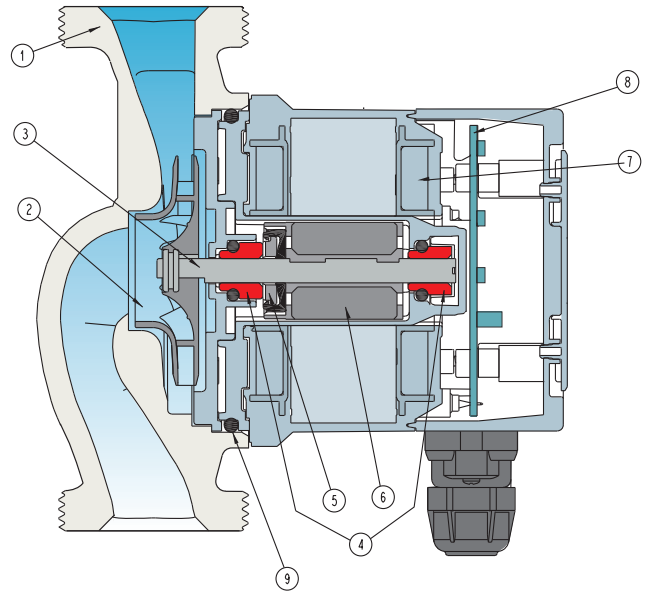

Dimensions and weights

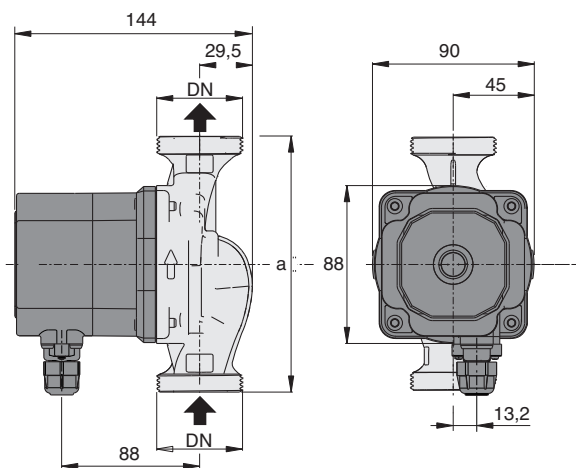

Unions (on request)

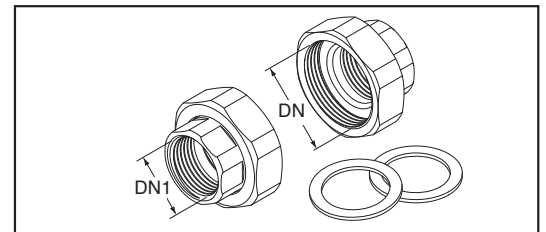

| TYPE | DN | 230V | | P1 | | mm a | Net weight kg |
|------------------|---------|-------|-------|-------|-------|---------|------------------|
| | | A max | A min | W max | W min | | |
| NCE ES 15-40/130 | G 1 | 0,35 | 0,03 | 44 | 4,5 | 130 | 2,15 |
| NCE ES 20-40/130 | G 1 1/4 | 0,35 | 0,03 | 44 | 4,5 | 130 | 2,25 |
| NCE ES 25-40/130 | G 1 1/2 | 0,35 | 0,03 | 44 | 4,5 | 130 | 2,35 |

| TYPE | DN | DN1 |
|-----------------------------------|---------|-------|
| KIT G 1 - G 1/2 (NCE ES 15..) | G 1 | G 1/2 |
| KIT G 1 1/4 - G 3/4 (NCE ES 20..) | G 1 1/4 | G 3/4 |
| KIT G 1 1/2 - G 1 (NCE ES 25..) | G 1 1/2 | G 1 |

Examples of installations

Installation

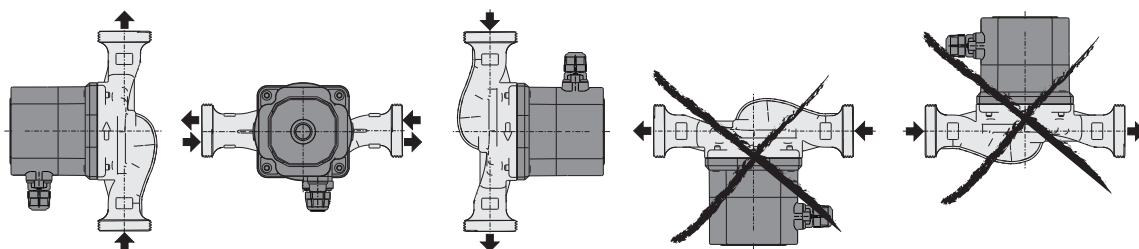

Terminal box arrangement (on request)

